

The flexible air quality solution
for commercial and light industry

AllerAir
AllerAir Industries

Model I-6500

recirculating air purifiers

More features
More Options
Less Cost
The AllerAir Guarantee



Filter any combination of dust particles,
chemicals, gases and microbiological toxins.

FILTERS

- HEPA filters 99.97% efficient to 0.3 microns
- 80 pounds of carbon
- Particle and dust pre-filter
- Specially selected chemical and gas phase filtration for specific gas solutions

BLOWER ASSEMBLY

- 2 speeds blower (350 to 1000 CFM)
- Factory balanced and tested to ensure quiet, vibration free
- Vibration adsorbing motor mounting operation

CONTROL PANEL

- Recessed, designed for easy monitoring.
- 2 position on/off switch
- Gauge for visual indication of filter pressure.
- 120 volts.
- Fuse protected

CABINET

- 20 gauge attractive powder coated steel cabinet for durability
- Non moving lockable
- 3" wheels for maneuverability

OPTIONAL UV LAMPS

- 20 Watts - \$300,
- 40 Watts - \$500,
- 60 Watts - \$700,
- 80 Watts - \$900,

***CUSTOM CONFIGURATION
AVAILABLE**



Model I-6500 A
(500 and 1000 CFM)

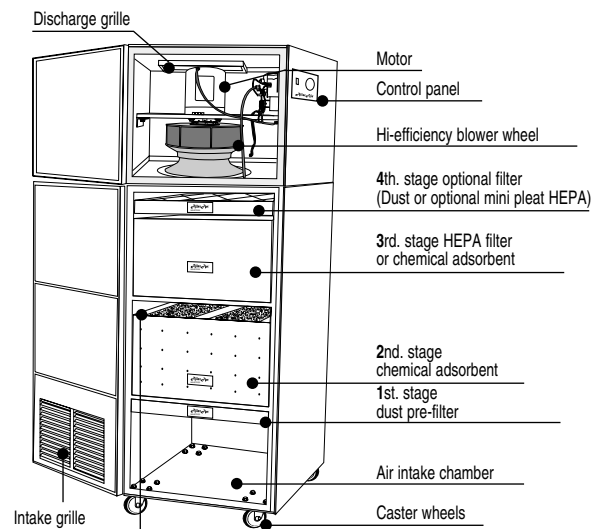

NOTE:
Carbon filter lid not in place
for visual appearance.
(You must attach lid to filter canister)

Easy refillable carbon filter

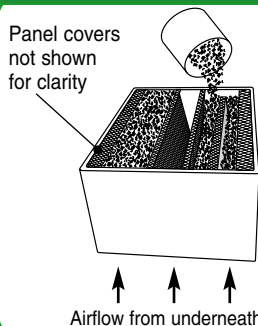

The Carbon Assembly is a perforated metal container, engineered to provide maximum air contact with the chemical filters.

An added feature of the carbon filter is the removable panel cover running the full depth of the unit for ease of filter loading.

Airflow pattern

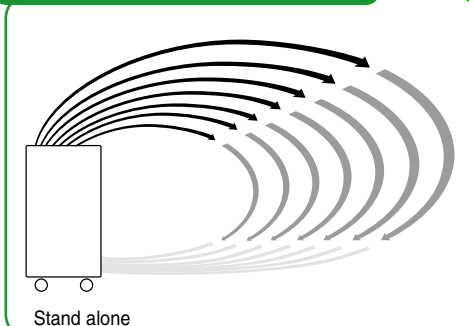

Toll free: 1-888-852-8247 / Fax: 1-877-688-2193 www.allerair.com

AllerAir